



SPECIFICATION

MODEL: 4292

1o Two Hole Sink Mixer with Crosshead Handles



- 1/4 turn ceramic disc flow control. • Vernier insert for accurate handle alignment.
- Unique handle construction with integral bearing ring

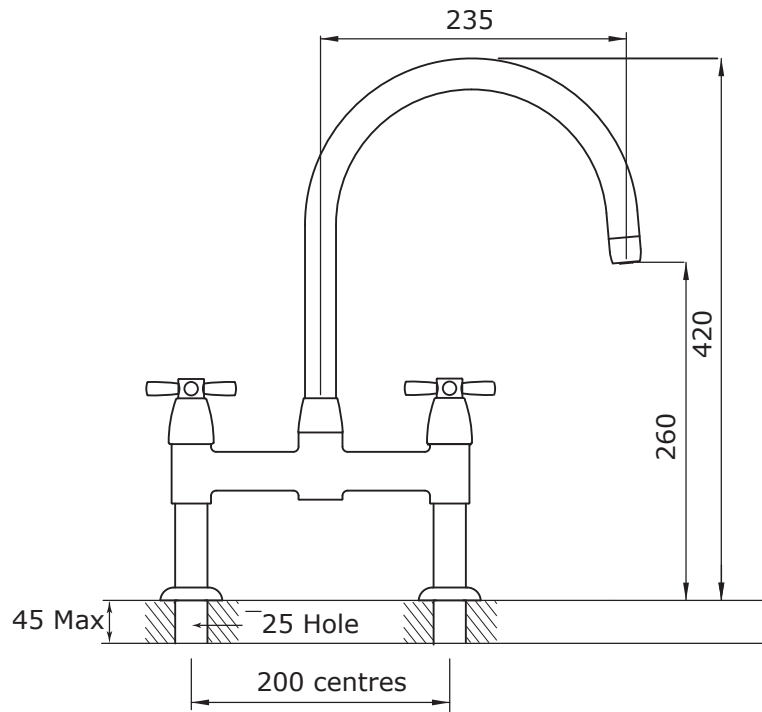

TEMPERATURE RANGE:

Min: 1°C / 34°F
Max: 85°C / 185°F

AVAILABLE FINISHES:

Chrome
Pewter
Nickel

RECOMMENDED WORKING PRESSURE:

Min: 0.2 bar/ 3psi
Max: 5 bar/ 75psi

ALTERNATIVE OPTION:

Lever Handles (4293)
Crosshead Handles with Rinse (4272)
Lever Handles with Rinse (4273)

TRIFLOW CONCEPTS BACK TO TAP