



SPECIFICATION

MODEL: AQUITAINE

Single Lever Monobloc Mixer



- Easy to operate single handle design
- Flexible connectors for easier installation.

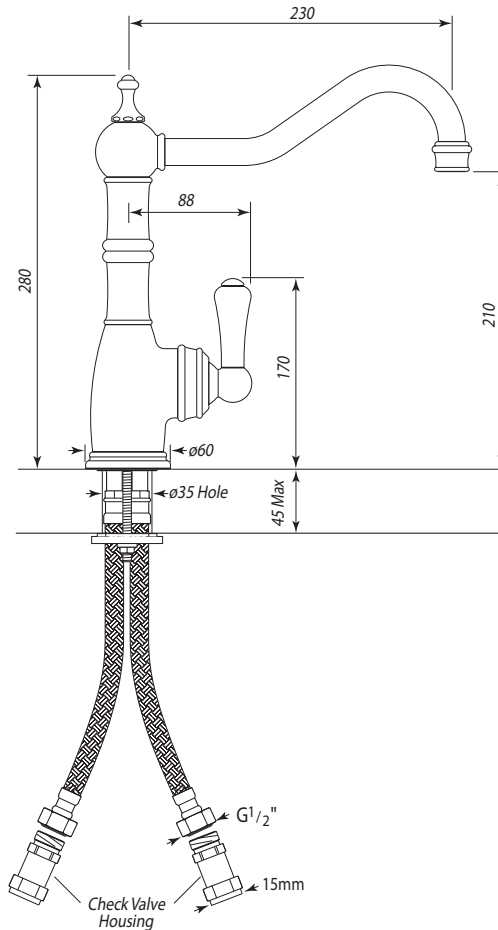

TEMPERATURE RANGE:

Min: 1°C / 34°F
Max: 85°C / 185°F

RECOMMENDED WORKING PRESSURE:

Min: 1 bar/ 15psi
Max: 5 bar/ 75psi

AVAILABLE FINISHES:

Chrome
Pewter
Nickel

TRIFLOW CONCEPTS BACK TO TAP