

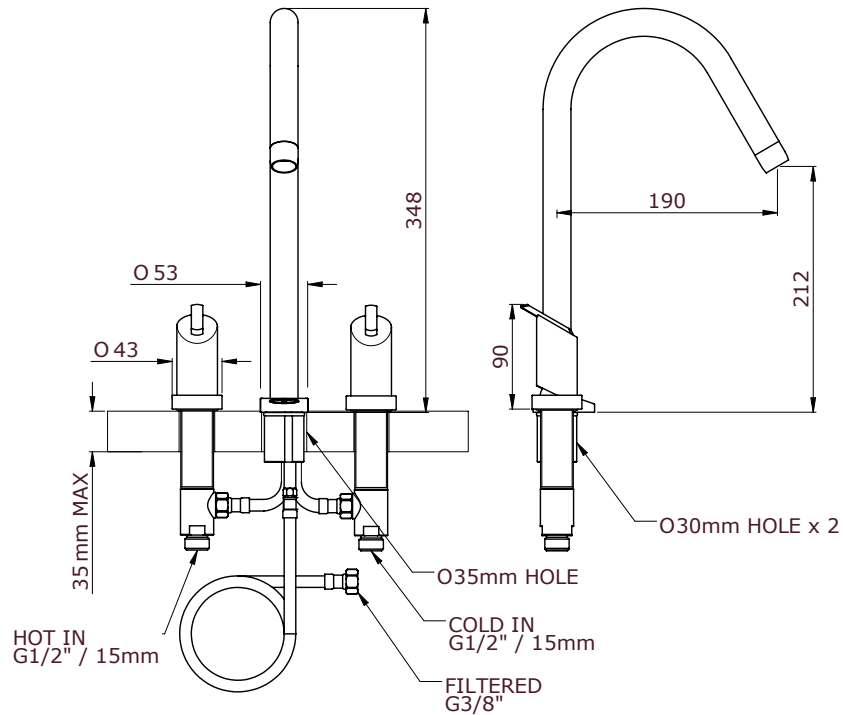

SPECIFICATION

- MODEL: TF-KTDW21E**
- Electronic Filter Housing
 - Swivel Spout
 - Separate Hot and Cold controls
 - Toggle Valves



TEMPERATURE RANGE:

Min: 1°C / 34°F
Max: 75°C / 167°F

AVAILABLE FINISHES:

Chrome
Pewter

RECOMMENDED WORKING PRESSURE:

Min: 1.5 bar
Max: 5 bar

ALTERNATIVE FORMATS:

Sink Mixer
Basin Triflow
Basin Mixer

Triflow Electronic System

Triflow Concepts introduce the latest evolution of their patented, three-way Triflow® technology – a unique touch-sensitive electronic button to activate the filtered water. Indicated by the subtle Triflow logo, the touch-sensitive button connects directly to a sleek electronic filter housing system which sits under the sink. This mains operated intelligent system makes the button glow green when activated and red when the filter needs replacing.

TRIFLOW CONCEPTS BACK TO TAP