

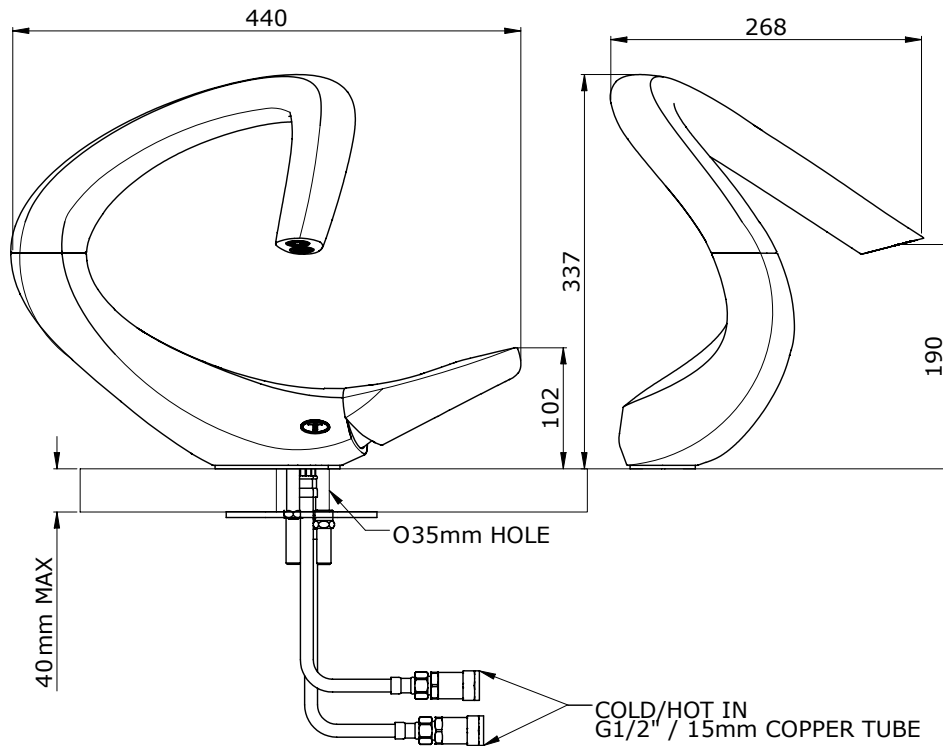

# SPECIFICATION

MODEL: 1808

- Electronic Filter Housing
- Zaha Hadid Design
- Inspired by flow of water
- Single lever Hot and Cold



## TEMPERATURE RANGE:

Min: 1°C / 34°F  
Max: 75°C / 167°F

## AVAILABLE FINISHES:

Chrome  
Nickel

## RECOMMENDED WORKING PRESSURE:

Min: 1.5 bar  
Max: 5 bar

## Triflow Electronic System

Triflow Concepts introduce the latest evolution of their patented, three-way Triflow® technology – a unique touch-sensitive electronic button to activate the filtered water. Indicated by the subtle Triflow logo, the touch-sensitive button connects directly to a sleek electronic filter housing system which sits under the sink. This mains operated intelligent system makes the button glow green when activated and red when the filter needs replacing.

TRIFLOW CONCEPTS BACK TO TAP

Triflow is a registered trademark of TRIFLOW CONCEPTS LIMITED.

WWW.TRIFLOWCONCEPTS.COM  
Triflow Concepts Limited, Gateway XIII, Ferry Lane, Rainham Essex, RM13 9JY, United Kingdom  
T: 0845 313 5000 , +44 (0)1708 526361 E: support@triflowconcepts.com